

SOLUTIONS INTERMEDIATE 4
UNIT 8: MESSAGES
8A

PEGAH BAHOJB GHASEMI



A satellite view of Earth at night, showing city lights and a blue horizon. The image is dominated by a deep blue color palette, with the Earth's surface appearing as a textured, glowing blue sphere. The horizon is a bright, curved line of light. The city lights are visible as a dense, glowing pattern of yellow and orange dots, primarily concentrated in the lower-left quadrant of the image. The text is overlaid on the upper portion of the image, in a bold, black, sans-serif font.

**IMAGINE A WORLD WITHOUT MOBILE
PHONES.
HOW DO YOU SEE THIS WORLD?**



1 SPEAKING Work in pairs. Choose a photo each and describe it to your partner. Then discuss the questions.

- 1 Do you mind if people talk on their phones in public places? Why? / Why not?
- 2 Do you think people rely too much on their phones? Why? / Why not?
- 3 Have you ever had problems getting a mobile signal? If so, where? What did you do about it?



**WHAT DO YOU
MOSTLY DO WITH
YOUR SMART
PHONES HAVE?**



MEASURE YOUR HEARTBEAT



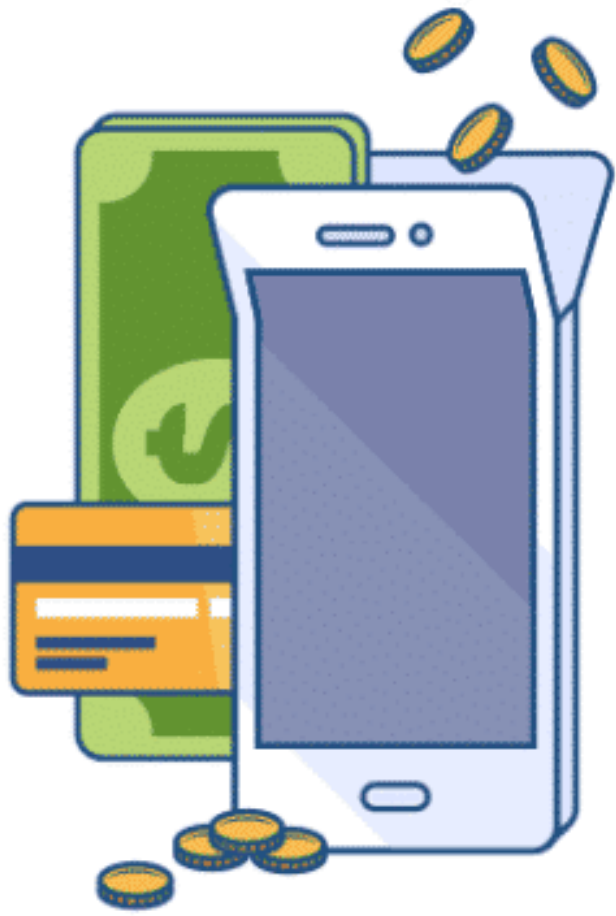

TOP UP: TO MAKE UP TO THE FULL QUANTITY, CAPACITY, OR AMOUNT.



2 KEY PHRASES Match a–f with 1–6 and g–l with 7–12.

Collocations: using a mobile phone

- | | | | |
|-------------|--------------------------|--------------------|---------------------------------------|
| 1 enter | a a number | 7 leave | g data roaming |
| 2 make | b the signal | 8 top up | h a message |
| 3 lose | c your phone | 9 disable / enable | i a call / somebody on
loudspeaker |
| 4 put | d a call | 10 save / add | j a number to the contacts list |
| 5 recharge | e your voicemail | 11 put | k your mobile |
| 6 listen to | f the phone on
silent | 12 run out of | l credit |

3  **3.11** Listen to four phone conversations. Answer the questions.

- 1 a Who does Ryan mistake Jodie for?
b What message does Ryan leave?
- 2 c Whose money does the boy use to top up his mobile?
d How much does the boy top up?
- 3 e Why didn't Jake receive his messages?
f Why didn't Jake answer his calls yesterday?
- 4 g What problem does the girl have?
h What solution does the boy suggest?

4  **3.11** Listen again. How many of the phrases in exercise 2 can you hear?



**WHAT IS THE PROBLEM WITH
USING DATA ROAMING WHEN
YOU'RE ABROAD?**

**2 IN WHAT SITUATIONS WOULD
YOU PUT YOUR PHONE ON SILENT?**

**3 IN WHAT SITUATIONS WOULD
YOU PUT YOUR PHONE ON
LOUDSPEAKER?**

**4 HOW OFTEN DO YOU RUN OUT OF
CREDIT?**

TO CONNECT WIRES FROM MACHINES TO A POWER SOURCE OR OTHER MACHINES.

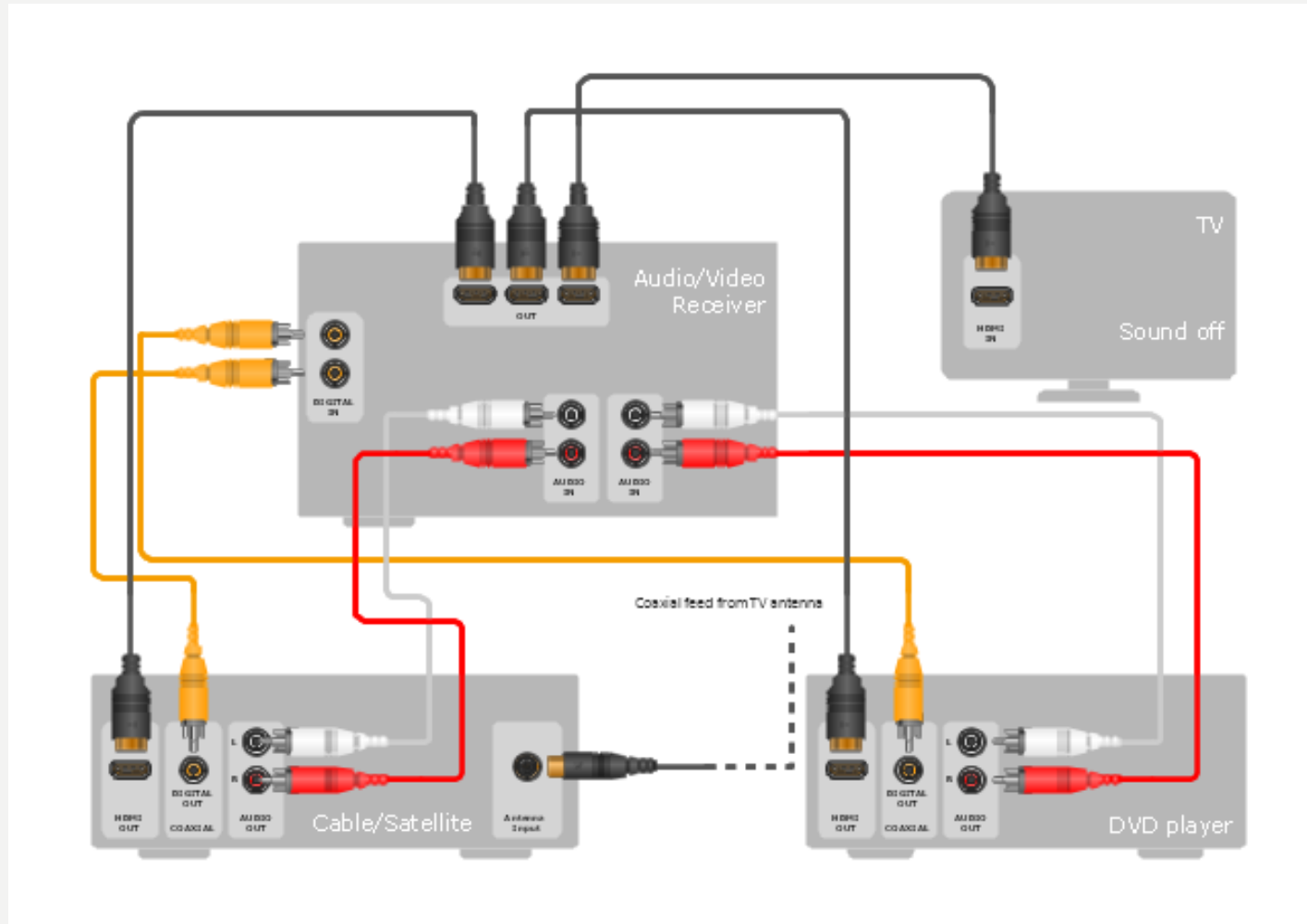

TO CONNECT WIRES FROM MACHINES TO A POWER SOURCE OR OTHER MACHINES.

HOOK UP

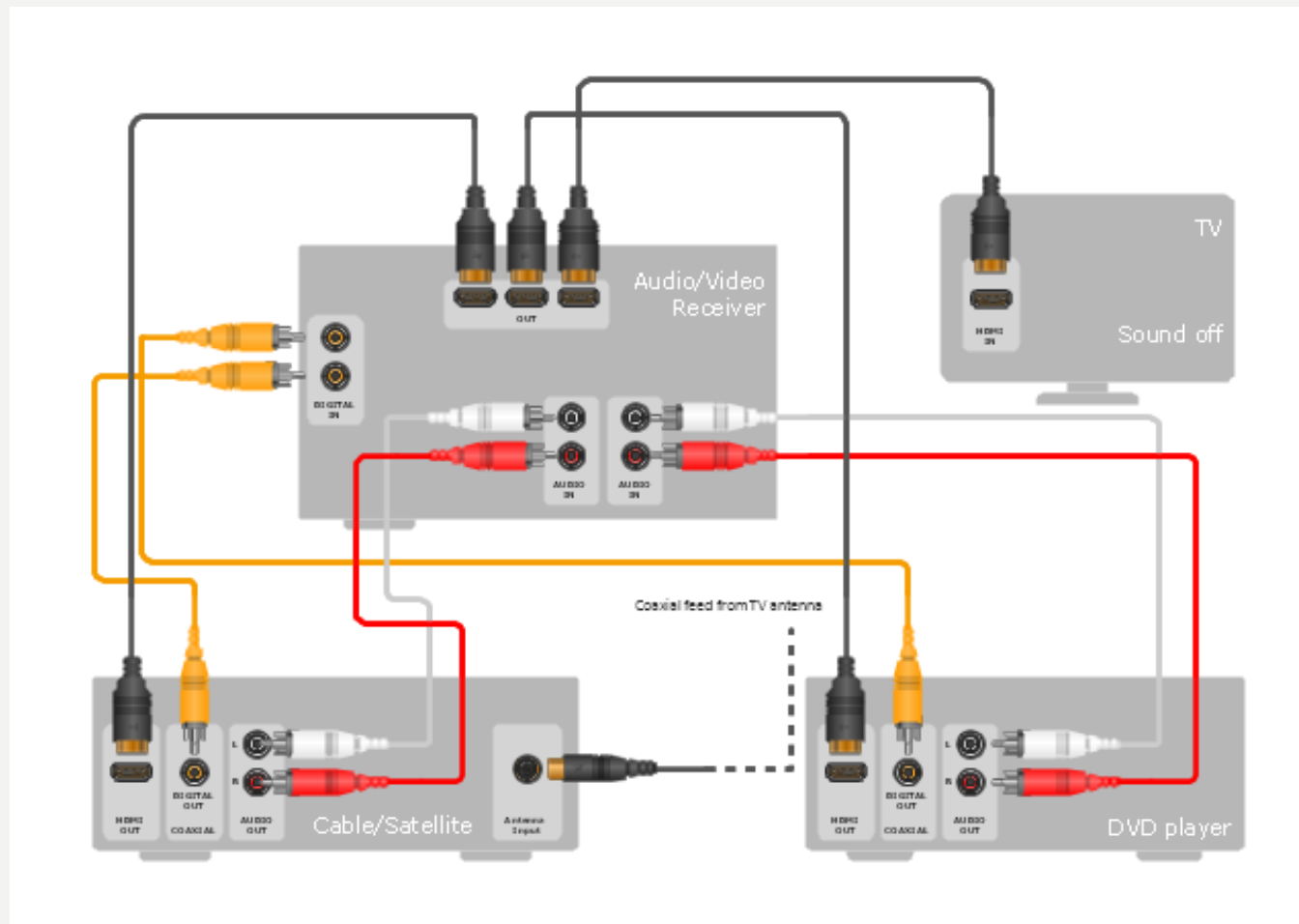

5 KEY PHRASES Match the phrasal verbs (1–10) with the definitions (a–j).

Phrasal verbs: phoning

- | | |
|----------------------------|---------------------------------------------------|
| 1 get through (to someone) | a turn something off |
| 2 pick up the phone | b phone somebody again later |
| 3 switch something off | c phone somebody again later |
| 4 speak up | d establish contact |
| 5 run out of something | e stop or interrupt somebody's phone conversation |
| 6 call somebody back | f have no more of something; finish something |
| 7 break up | g answer a call |
| 8 cut somebody off | h become unclear and difficult to understand |
| 9 hang up | i end a phone call |
| 10 get back to somebody | j talk more loudly |



**SWITCH OFF YOUR
PHONE.**

**GET THROUGH TO YOUR
MOTHER.**



**SWITCH OFF YOUR
PHONE.**

**GET THROUGH TO YOUR
MOTHER.**



**SWITCH OFF YOUR
PHONE. (IT)**

**GET THROUGH TO YOUR
MOTHER. (HER)**



SWITCH IT OFF.

GET THROUGH TO HER.



SWITCH IT OFF.

Separable

GET THROUGH TO HER.

Inseparable

RECYCLE! Phrasal verbs

- With separable phrasal verbs, the object can come **before** or **after** the particle, but when the object is a pronoun (*her, it, them, etc.*) it must come **before** the particle.
switch the phone off / switch off the phone
switch it off / ~~switch off it~~ X
- With inseparable verbs, the object always comes **after** the particle, even when it is a pronoun.
- Three-part phrasal verbs are always **transitive** and **inseparable**. The object always comes after the two particles.
get back to somebody

6 Read the **Recycle!** box and answer the questions.

- 1 Which phrasal verbs in exercise 5 are transitive?
How do you know?
- 2 Which have three parts?
- 3 Which are separable? How do you know?

7  **3.12** Listen to a phone conversation. Answer the questions.

- 1 Why couldn't the two people talk earlier?
- 2 What two reasons do they have for ending the call?

8  3.12 Complete the extracts from the conversation with a verb and one or two particles. Then listen again and check.

- 1 I've been trying to call, but I couldn't _____.
- 2 The phone rang, but I couldn't _____.
- 3 The teacher told me to _____ the phone
_____.
- 4 Can you _____? I can't hear you very well.
- 5 Look, I'm _____ credit. Can I _____ you
_____?
- 6 You're _____.
- 7 OK, I'll _____ and _____ you.

9 SPEAKING Work in pairs. Ask and answer the questions.

- 1 Do you have a mobile phone? If so, how long have you had it? Who pays for the calling plan and / or the calls?
- 2 How often do you use your phone? How long do you spend on your phone each day?
- 3 How many texts do you send per day, on average? Who do you send them to?
- 4 If you're phoning someone from your home, are you more likely to use a mobile phone or the landline? Why?
- 5 Would you find life difficult without mobile phones? Why? / Why not?

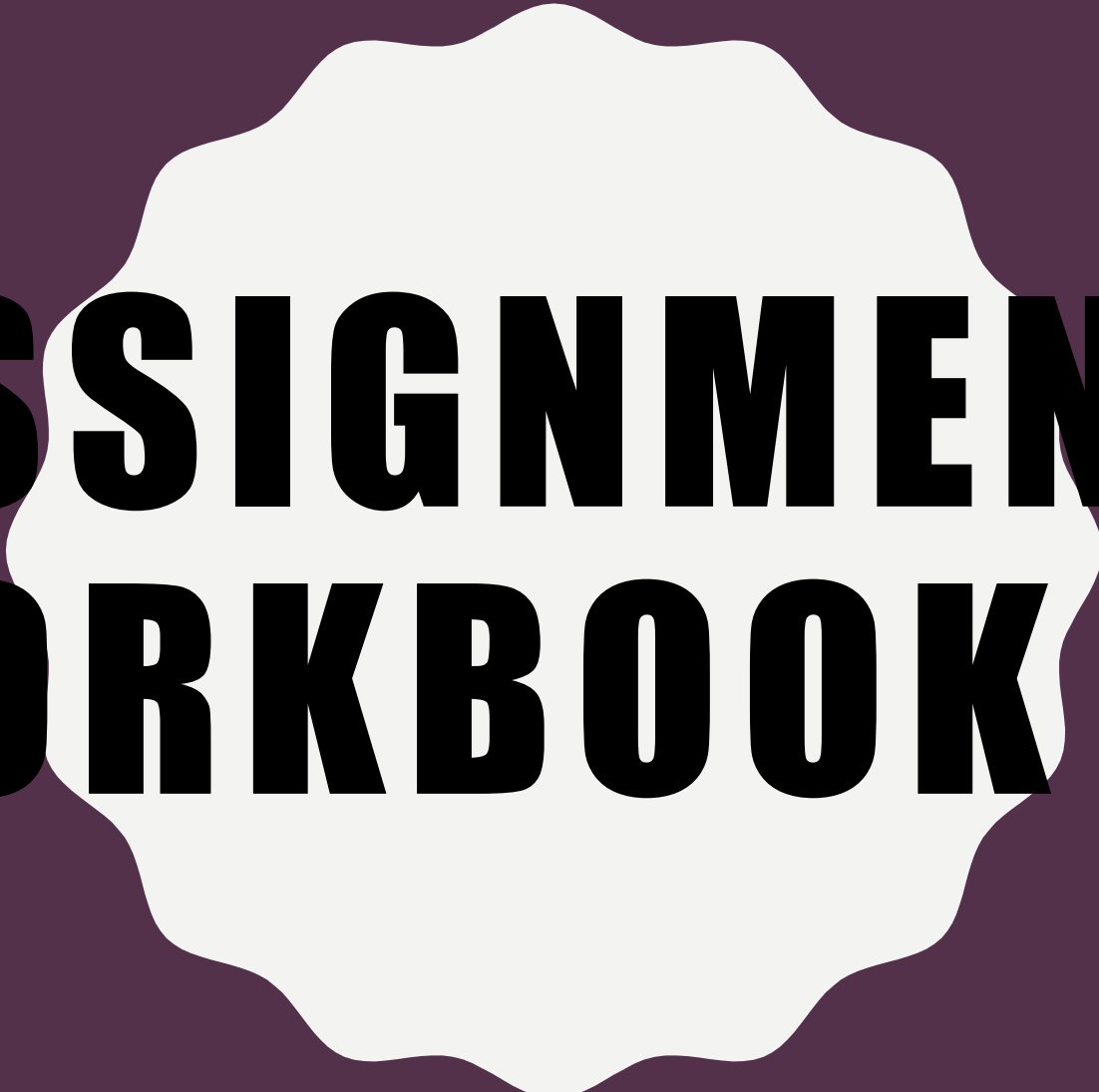

**ASSIGNMENT:
WORKBOOK 8A**

DEADLINE: SATURDAY