

SOLUTIONS PRE-INTERMEDIATE 3
UNIT 5: AMBITION
5B

PEGAH BAHOJB GHASEMI

5

Ambition

Vocabulary

A

Jobs

I can talk about jobs and work.

1 Read the definitions and complete the puzzle.

This person:

- 1 helps people to look after their teeth.
- 2 writes computer software.
- 3 flies an aeroplane.
- 4 often looks after cows and other animals.
- 5 cuts people's hair.
- 6 helps people who are injured or ill in an emergency.
- 7 trains a person or team to make them better at a sport.
- 8 deals with people who arrive at a hotel, an office, etc.
- 9 designs and builds road, bridges, machines, etc.
- 10 helps people when they buy a house or have a legal problem.
- 11 designs buildings.
- 12 helps people to choose a holiday.
- 13 cleans people's offices, houses, etc.
- 14 brings food and drink to tables in a restaurant or café.

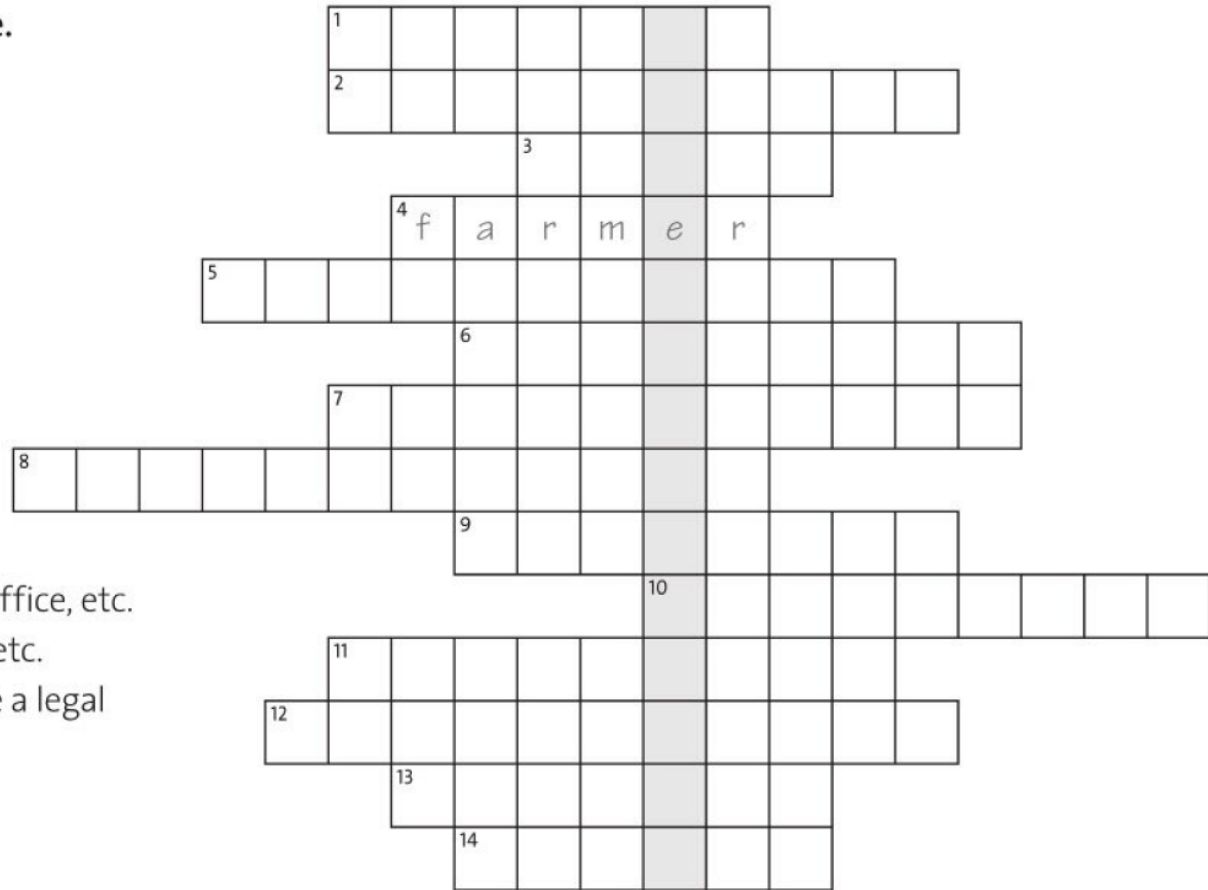

2 Complete the work activities with the words below. Use each word or phrase only once.

alone children a computer customers your feet
five hours indoors a lot a lot of money outdoors
the phone phone calls the public a team a uniform

- 1 travel _____
- 2 be on _____
- 3 serve _____
- 4 work _____
- _____
- _____

- 5 wear _____
- 6 deal with _____
- 7 be part of _____
- 8 work nine-to-_____
- 9 work long _____
- 10 make _____
- 11 answer _____
- 12 work with _____
- 13 earn _____
- 14 use _____

3 Complete the adjectives for describing jobs with *a, e, i, o, u* and *y*. Then use them to complete the table.

1 challenging

6 str__ssf__l

2 b__dl__ p____d

7 t__r__ng

3 cr____t__v__

8 v__r____d

4 r__p__t__t__v__

9 w__ll p____d

5 r__w__rd__ng

Positive 😊	Negative ☹️
challenging	

- 4  1.17 Listen to three people talking about their jobs. What are the jobs? Choose two adjectives from exercise 3 which you think best describe each job.

Job	Adjective 1	Adjective 2
1		
2		
3		





I WANT TO ...

.



**WHAT DO YOU
WANT TO DO AT
THE WEEKEND?**



1 Describe the photo. How do you think the girl is feeling?

2  2.08 Read and listen to the dialogue.



Toby Hi, Mia. Is anyone sitting here?

Mia Hi, Toby. No. Sit down, I'll move my bag.

Toby Thanks. Are you OK? You look a bit anxious.

Mia I've got a job interview in twenty minutes.

Toby Oh! I won't chat, then, I promise!

Mia It's OK. I'm going to leave soon anyway. I need to walk to Hill Top Road. Is it far?

Toby Not really. It'll take about ten minutes.

Mia Oh no. Look at that rain! I'm going to get wet!

Toby I'll lend you my umbrella.

Mia It's OK. I'll call a taxi.

Toby There isn't time for that. Here, take it.

Mia Thanks. I'll give it back later. Where will you be?

Toby I'll wait here for you. Good luck!





- A. It is going to snow
- B. It will snow.

- 
- A photograph of a suspension bridge, likely the Golden Gate Bridge, during sunset. The sky is a deep orange, and the bridge's steel structure is silhouetted against the light. In the foreground, the dark silhouette of a multi-story building is visible on the left side. The overall mood is serene and atmospheric.
- ✓ It is going to snow
 - ✓ It will snow.

WHICH ONE IS CORRECT?

- A. I promise you that I'm going to call you.
- B. I promise you that I will call you.

WHICH ONE IS CORRECT?

- A. I promise you that I'm going to call you.
- B. I promise you that I will call you.

- 3 Read the **Learn this!** box. Then find all the examples of *will* and *going to* in the dialogue in exercise 2.

LEARN THIS! *will* and *going to*



a For predictions, we use:

1 *going to* when the prediction is based on what we can see or hear.

Look at those clouds! There's going to be a storm.

2 *will* when the prediction is based on what we know or is just a guess.

I (don't) think the weather will be warmer next month.

b For plans, we use:

1 *going to* when we have already decided what to do.

I'm going to stay in tonight. I've got the DVD ready!

2 *will* when we are deciding what to do as we speak.

Somebody's at the door. I'll see who it is.

c For offers and promises, we use *will*.

I'll phone you later. I won't forget.

4 Match each example of *will* and *going to* in the dialogue with a rule in the **Learn this!** box.

5 Complete the second part of the dialogue with the correct form of *will* or *going to*. Who do you think will be more successful in the future?

6  **2.09** Listen and check your answers. How is the word *to* pronounced in *going to*?

Mia Here's your umbrella.
Toby Thanks. Well? ¹Are you going to tell (you / tell) me about the interview?
Mia I got the job! I ²_____ (start) on 1 August! It's just for the summer.
Toby What ³_____ (you / do) after that?
Mia I ⁴_____ (study) maths at university. Then I ⁵_____ (get) a job in finance. That's the plan.
Toby Why finance?
Mia It pays well. My salary ⁶_____ (be) quite high.
Toby Do you think it ⁷_____ (be) rewarding?
Mia I don't know, Toby. At the moment, I'm more interested in being successful.
Toby Me too. That's why I ⁸_____ (not do) a degree.
Mia I don't think you ⁹_____ (get) a very good job without a degree.
Toby I ¹⁰_____ (not apply) for a job. I ¹¹_____ (start) my own business.
Mia What kind of business?
Toby A web-based marketing company. I predict I ¹²_____ (be) a millionaire before I'm 25!
Mia Really?
Toby It ¹³_____ (not be) easy. But I'm confident.
Mia Well, good luck!

I'LL PROBABLY BE AN ENGINEER.

Certainty level:

A. Sure

B. Not sure

I'M DEFINITELY GOING TO BE AN ENGINEER.

Certainty level:

A. Sure

B. Not sure

LOOK OUT!



We can make predictions and plans more certain or uncertain by adding *definitely* or *probably*. Pay attention to the position of the adverb.

I'll *definitely* / *probably* apply for a summer job.

I *definitely* / *probably* won't earn very much.

I'm *definitely* / *probably* (not) going to travel.

7 Read the **Look out!** box. Then make notes about your own future. Write down:

- a job you will probably do some time in the future.
- a job you will definitely never do.
- something you're probably going to eat this evening.
- something you're definitely not going to do this evening.
- something you're probably going to buy soon.
- a place you will probably visit this year.

8 SPEAKING Work in pairs. Talk about your plans and predictions from exercise 7. Use *will* and *going to*.

I'll probably work in a café some time in the future.

I'll probably work in my parents' shop.

5A

Jobs

1 Match the jobs with the pictures.

cleaner dentist farm worker pilot programmer sales assistant
solicitor sports coach travel agent waiter

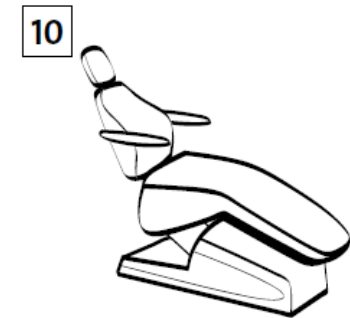
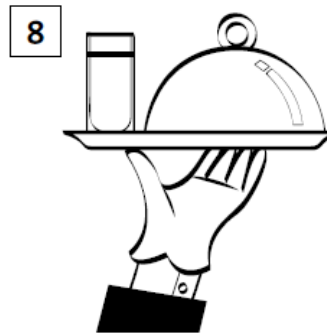
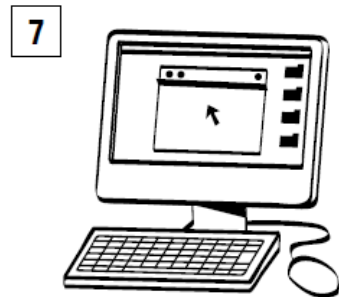
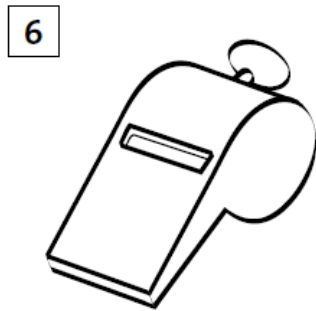
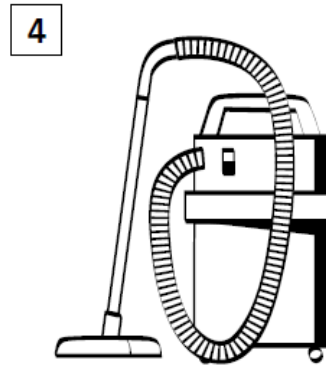
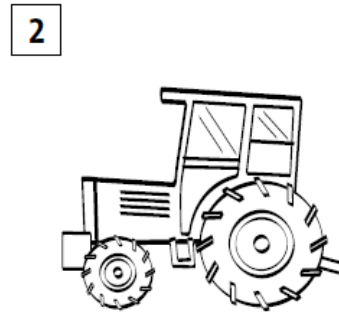
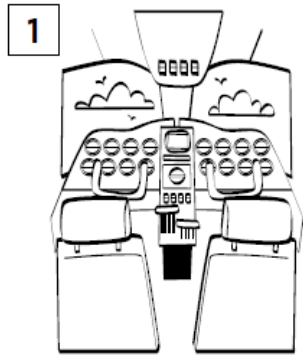

2 Who says these things? Use the words from exercise 1. Then write sentences for the two other jobs from exercise 1.

1 'These jeans are £25.'

2 'There's a great deal on flights to Paris at the moment.'

3 'Would you like to see the menu?'

4 'Open your mouth, please.'

5 'We are now flying over the Atlantic Ocean.'

6 'Where's the vacuum cleaner?'

7 'The cows are all under the trees.'

8 'Run three times around this field.'

3 SPEAKING Work in groups of four. Play 'Guess my job'.

Student A Think of a job from exercise 1.

Students B, C & D Ask Student A *yes/no* questions about the job. Can you guess the job?

Do you work outdoors?

B

Yes, I do

A

Do you earn a lot of money?

C

No, I don't.

A

Is it a tiring job?

D

Yes, it is.

A

Are you a farm worker?

B

ASSIGNMENT:
WORKBOOK 5B
GRAMMAR BUILDER
P.132

DEADLINE: SATURDAY